

Canada Specialty Products

A WORLD OF ROOFING PRODUCTS AVAILABLE
THROUGH LEADING DISTRIBUTORS

| | | | |
|-----------------------------|--------|-------------------------------|-------------------|
| Adhesive Applicator, Mini | 55 | Moisture Detectors | 77 |
| Adhesive Dispenser | 55 | Mop Bellhead | 58 |
| Asphalt Skimmer | 58 | Mop Staple | 58 |
| Bandmaster | 64 | Non-Powered on Deck Equipment | 48, 51, 53-55, 61 |
| Belts | 72 | Patch Kettles | 48 |
| Blowers | 69 | Patch Pot, 55-gal Insulated | 48 |
| Brakes & Accessories | 66-68 | Peeler | 44 |
| Buckets, Asphalt | 56 | Pigtail Hook | 40 |
| Carriers, Utility | 53-54 | Pitch Finder | 78 |
| Chariot Cart | 44 | Planers | 43 |
| Chimney Caps | 59 | Powered on Deck Equipment | 42-44 |
| Core Cutter | 60 | Propane Carrier | 52 |
| Cut-off Wheels | 72 | Pump Jacks | 87 |
| Cutters | 42 | Roll Carrier | 53 |
| Dipper | 59 | Rollers & Frames | 58, 60 |
| Dumper | 52 | Rolling Tool Box | 61 |
| Engines | 70 | Roof Brackets | 59 |
| EPDM Accessories | 53 | Roof Hatch & Safety Rail | 57, 89 |
| Fork Cart | 51 | Roofing Scrapers | 58 |
| Ginwheel | 40 | Seamers | 58 |
| Granular Embedment Tool | 60 | Sheet Metal Equipment | 64-66 |
| Gravel Buckets | 40 | Shingle Removers | 71 |
| Gravel Pusher | 59 | Shingle Shear | 78 |
| Gravel Spreader | 54 | Slitter | 65 |
| Graveler | 44 | Soldering Pots | 74 |
| Hand Hoist | 38 | Sprayer | 72 |
| Hand Rollers | 60 | Spreader Sling Assembly | 40 |
| Heating Cables | 88 | Steel Cable & Accessories | 88 |
| Hoist Accessories | 38, 40 | Tank, 55-Gal Insulated | 48 |
| Hoist Cable | 88 | Tear Off Bar | 52 |
| Hoists | 36-39 | Thermometer | 50 |
| Hot Air Welders | 74-76 | Tire, Flat Free | 52 |
| Infrared Thermometer | 75 | Tool Holders | 71 |
| Job Box | 61 | Torches & Accessories | 73 |
| Kettle Accessories | 50 | Trailers | 62-63 |
| Kettles | 66-69 | Trash Removal System | 41 |
| Ladder Jacks | 87 | Trash Trays | 40 |
| Ladders & Accessories | 79-86 | Truck Racks | 85-86 |
| Lite Lift Wheel | 40 | Water Pumps | 57, 78 |
| Lok-Former | 64 | Wheel Barrows | 51 |
| Mini Mopper | 55 | Wheels | 72 |
| Modified Bitumen Hip Hugger | 60 | | |
| Modified Bitumen Roll Hook | 60 | | |

E-MAIL

info@canadaspecialty.com

WEB

www.canadaspecialty.com



We manufacture two styles of ladder hoists. Why? – Because that's what our customers asked for. Some customers prefer the styling and benefits of the LH Series, while other customers prefer the LPH Series. Both hoists incorporate similar design features such as our superior band brake system, heavy duty ladder sections and splice plates and high quality, heavy duty componentry, providing you durability and long life.



LH-250 Ladder Hoist

Features

Superior Band Brake System

- self locking brake with non-asbestos brake pad and steel brake drum
- foot control belt clutch with one hand operation
- sealed ball bearing wheels, pulleys and sheaves for longer machine life
- self contained 16' ladder hoist needs no assembly
- 200 lbs. capacity

Options

- gravel hopper
- roller angle guide
- telescopic ladder support for heights over 28 feet
- additional ladder sections
- power drives:
 - 3.5 HP Briggs & Stratton engine
 - 4 HP Honda engine
 - 1.5 HP Electric 110-220 60 cycle

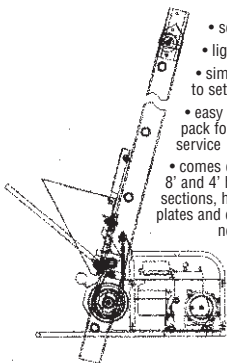

- sets up in minutes
- light, easy to carry
- simple for one man to set up and operate
- easy access to power pack for maintenance and service
- comes complete with 16', 8' and 4' heavy duty ladder sections, heavy duty splice plates and everything you need to get the job done
- ladder sections can extend height to 44' with telescopic support



LPH Ladder Platform Hoists



Features

- easy to operate and assemble
- lightweight and portable
- easy access to power pack for maintenance and service
- comes complete with 16', 8' and 4' heavy duty ladder sections, heavy duty splice plates and everything you need to get the job done
- ladder sections can extend height to 44' with telescopic support

Superior Band Brake System

- self locking brake with non-asbestos brake pad and aluminum brake drum
- far superior to similar style ladder platform hoists
- sealed ball bearing wheels, pulleys and sheaves for longer machine life

Options

- gravel hopper
- roller angle guide
- telescopic support for heights over 28 feet
- plywood/panel carrier attachment
- additional ladder sections
- power drives:
 - 3.5 HP Briggs & Stratton engine
 - 4 HP Honda engine
 - 1.5 HP Electric 110-220 60 cycle



Gravel Hopper

Clamps on platform and discharges gravel when it reaches top of ladder.



Roller Angle Guide

Designed for receiving shingles at top of ladder.

LPH-400

Load Capacity
200 lbs.

Lift speed
220 fpm

Platform size
17" x 18"

Ladder width
17"

LPH-250

400 lbs.

110 fpm

24" x 28"

24"



Telescopic Ladder Support

Extra support for ladder on heights above 28 feet.

Safe Operation

- operator stands well back from moving platform
- two handles work independently to eliminate operator error
- single handle brake operation, single handle clutch operation

EASTERN CANADA

1-888-749-7777

WESTERN CANADA

1-866-338-7727

Trolley Track Hoist

Heavy duty design with 9 HP Honda engine power unit for TT 1000.

Height adjustment on front and rear legs.

Superior band brake system including aluminum brake drum with non asbestos brake pad.

Equipped with heavy duty flanged self locking bearings for longer machine life.

Power unit controlled by two levers with safety ratchet and pawl to prevent load from accidental lowering during operation.

Easily assembles on the roof in minutes with self locking pins.

Available in heavy duty TT 1000 lbs. version or TT 400 lbs. for smaller requirements.

Also available: hydraulic power pack and ground mount power pack.

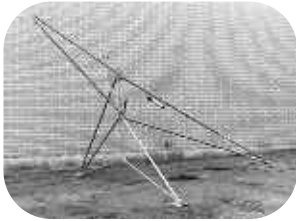

Hand Swing Hoist

- light weight and is easy to transport and assemble
- swing boom can be assembled to swing left or right
- self locking latch that locks and holds the boom in position during operation
- equipped with heavy duty oil-impregnated bronze bearings for smooth operation
- 300 lbs. capacity



Hoist Counterweights



- concrete filled
- galvanized steel encased
- pre-punched for positive nesting
- approx. weight 55 lbs.



- empty counterweight casing
- ideal for shipping
- customer can fill later



- all steel
- thin design
- will not shatter or break like concrete
- approx. weight 55 lbs.

"A" Frame Hand Hoist

- the most economical option for small job hoisting requirements
- light weight and easy to transport and set up
- 300 lbs. capacity

Hydraulic Swing Hoists

Features

- designed for easy operation
- provides excellent lifting performance
- easy maintenance
- puts you in complete control of load

Easy to Assemble and Operate

Hydraulic hoists can be easily transported and assembled. Handling loads up to 2000 pounds can be accomplished with ease and safety. Separate power and winch allows for easy handling of components. Power up and down and in and out puts the operator in complete control.

Features

Safety

- operator fence for operator safety
- swing boom allows load to be moved well away from roof edge
- hydraulically locked boom
- smooth up and down and in and out control

Specifications

| | HS1000 | HS2000 |
|---------------------------------------|--------------|--------------|
| Maximum Capacity Double Line | 1000 lbs. | 2000 lbs. |
| Maximum Capacity Single Line | 500 lbs | 1000 lbs |
| Hoist speed (maximum) | 150 ft./min. | 170 ft./min. |
| Cable length supplied | 200 ft. | 200 ft. |
| Overhangs roof | 55 in. | 60 in. |
| Hoist maximum height | 124 in. | 140 in. |
| Boom weight | 70 lbs. | 92 lbs. |
| Mast assembly weight | 120 lbs. | 145 lbs. |
| Ballast leg assembly weight | 130 lbs. | 140 lbs. |
| Winch weight | 100 lbs. | 100 lbs. |
| Power unit weight | 245 lbs. | 260 lbs. |
| Ballast weight required | 1250 lbs. | 2500 lbs. |
| Ballast block required (55 lbs. each) | 23 pcs. | 46 pcs. |

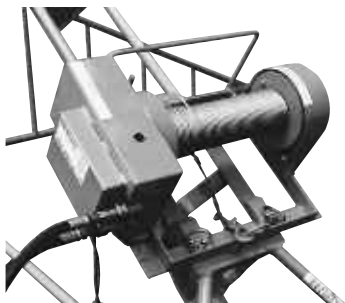

Winch

Design

- high strength tubing
- no special tools required for assembly
- split frame for portability

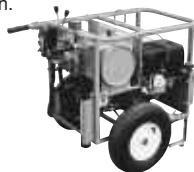

Power Pack

E-MAIL

info@canadaspecialty.com

WEB

www.canadaspecialty.com

Hoist Forks

- available in 400 lbs., 800 lbs. and 2000 lbs. capacity. Retaining brackets can be folded out to form a cradle for rolls on the 800 lbs. and 2000 lbs. capacity.



Lite Lift Wheel

- for hoisting applications

Ginwheel

- for hoisting applications



Trash Trays

- for safely loading and lowering debris



- 800 lbs. capacity



- 1200 lbs. capacity

Spreader Sling Assembly

- helps avoid tipping and sliding of large single ply rolls by evenly distributing the load
- comes complete with slings



Pigtail Hook

- for safely hoisting buckets and pails
- pails will not slide off



Gravel Buckets



- 400 gravel bucket
- bottom discharge dump gate can be operated from handles on either side
- 400 lbs., 3-1/2 cu. ft. capacity



- 800 gravel bucket
- bottom discharge with positive dump gate
- 800 lbs., 7 cu. ft. capacity



- 1600 gravel bucket
- 1600 lbs., 14 cu. ft. capacity

Trash Removal System

A fast, safe and dust-free way to remove debris, old roofing, sweepings, etc., from the roof or other elevated levels.

Easy to set up, take down, store and transport.

Quickly pays for itself in man-hour savings.

Welded steel hopper stands up to punishment and provides 42" x 42" depository (weighs 200 lbs).

Trash Chutes

Tough 4-foot chute sections are not affected by sunlight, moisture or chemical corrosion (weight: 27 lbs each).



Trash Hopper Counterweight System

- comes complete with operator safety fence
- easy to set up; provides a safe holding system for trash hopper and chutes
- comes complete with counterweights

EASTERN CANADA
1-888-749-7777

WESTERN CANADA
1-866-338-7727

Roof Sweeper

Has a convenient 3-position control for brush angles that is spring-loaded with gates for positive positioning of brush from straight to right or left.

Floating power brush design assures positive bristle contact with all surfaces for more efficient cleaning and longer brush life. Interlinked power controls automatically disengage whenever the operator's hands are removed from the handle.



Low Profile Roof Cutter

- light weight and equipped with 5.5 HP Honda engine
- ideal for cutting jobs around tight and hard to reach areas such as air conditioners and vents
- makes close cuts to skylights, parapets, etc.
- 12 inch blade with two carbide tipped cutters for longer blade life



Single Cutter

- heavy duty construction pays special attention to detail, performance, reliability and minimum maintenance
- designed with flanged bearings for longer machine life
- special benefits include a blade with two carbide-cutting tips for more cutting between changes and an adjustable cutting depth control handle
- available with either 8 HP Briggs & Stratton IC (industrial/commercial) engine or Honda 9 HP or 11 HP overhead valve engine



Double Cutter

- double blade version of our single cutter

Rotary Planer

- heavy duty design with 11 HP overhead valve Honda engine
- adjustable cutting depth
- equipped with heavy duty flanged block bearings for longer machine life
- cuts 14 inch path with 4 carbide tipped cutters mounted on solid steel circular plate
- cuts close to walls, gravel stops, roof edges, etc.
- safety splash guards for operator protection

**Patch Planer**

- heavy duty design with 5.5 HP Honda overhead valve engine
- cuts 4-1/2 inch path with 8 carbide tipped pins on 4 inch diameter solid steel drum
- easy access to drum assembly for maintenance through the safety cover
- adjustable cutting depth
- ideal for repair work around gravel stops, expansion joints and flashing
- drum rotation provides self-propulsion
- safety splash guards for operator protection

**GP15 Planer**

- heavy duty design with 9 HP Honda engine
- cuts 15 inch path with 30 carbide tipped pins on 4 inch diameter solid steel drum
- drum rotation provides self-propulsion
- adjustable cutting depth
- easy access to drum assembly for maintenance through the top service door
- safety splash guards for operator protection





Roof Peeler

- Heavy duty design with 11 H.P. electric start Honda engine
- Hydrostatic drive for variable speed forward and reverse
- Oscillating and adjustable blade, ready to tear off any type of roof
- Solid rubber tires
- Easy blade changes
- Hinged cover allows for easy access to all components for maintenance.



Power Graveler

This versatile machine is designed to accept different attachments such as a gravel bucket, dumper tray or 55 gal. hot tank.

Equipped with high flotation tires on a wide wheel base and powered by a 5.5 HP Honda engine.

The wheels and gears are direct chain drive equipped with a brake.

Brake automatically engages for safety whenever the operator's hand leaves the control.



Dumper Tray Attachment

Designed for hauling and unloading debris. Power graveler attachments can easily be changed over in minutes.



Power Graveler with no attachments



Chariot Cart

This ride-on attachment prevents operator fatigue and allows for quicker production.

Powered by



SPAR-Marathon equipment is available either powered by Honda engines or Briggs & Stratton.

Canada Specialty Products

The name SPAR-Marathon is synonymous with top performance roofing kettles:

- minimal maintenance and easy servicing
- fast, accurate heating
- safer, more efficient operation
- heavy duty quality construction

Benefits

Easy Loading – the low profile makes loading simple and fast.

Maximum Productivity – the complete insulation, unique circulating pump and other features ensure efficient, continuous operation.

Temperature Accuracy – stem-type thermometer helps determine and maintain optimum temperature.

Fast Heating – the SPAR-Marathon heating design speeds heating so jobs can start sooner. SPAR-Marathon kettles do what you need them to do best... achieve operating temperature quickly and holds it accurately. The unique recirculating system, the burners, insulation and other SPAR-Marathon design features are why even our smaller models can heat most asphalt to 500°F in under 30 minutes.

Better Towing – the rugged, wide-track frame and low profile make towing easier and safer.

Safer Operation – special splash guards help prevent accidents and costly delays – the key to profitable operation is efficient production with minimal delay. SPAR-Marathon kettle pumps, splash guards, brakes, drain-cocks, jacklegs, etc., are designed and manufactured for maximum performance, safety and roofer's profit.

Ideal Asphalt Consistency – SPAR-Marathon's special recirculating system maintains proper consistency throughout the job. Tube coking and sludge formations are reduced.

Constant, Even Heat – cold spots are minimized by the constant circulation of the asphalt.

Faster, Easier Maintenance – access to all parts requiring regular service is simple, with some parts being easily removed to speed maintenance. SPAR-Marathon has applied its on-the-job roofing experience to innovate, design and modify its kettle equipment to a point where maintenance and service downtimes are minimal. All parts of SPAR-Marathon Roofing Kettles which require regular maintenance are readily accessible. Servicing may also be accomplished without difficulty.

Standard Features:

Recirculating System – SPAR-Marathon's unique system for recirculating asphalt maintains ideal consistency and temperatures throughout the operation (available on all models except the MK 180 and MK 90 Skid Kettle).

- all asphalt achieves designated temperature faster
- constant circulation of asphalt reduces sludge formations and tube coking
- even, constant heat minimizes "cold spots"
- recirculating valve – an efficient, non-clog valve supplied with all models 250 gallons or greater

KK124 Pump – MPK models supplied with KK124 pump (plus 2" line and 9 HP Honda or 8 HP Briggs & Stratton engine) with a potential to pump 57 U.S. gpm to 150-200 ft. height. Consult with SPAR-Marathon for all uses above 60 feet.

Insulated Vat – fully insulated vat (fibreglass 575°F) prevents unsafe and costly heat loss.

Nylon Coupling – nylon coupling between the pump and the engine reduces problems caused by expansion or other movements of these components.

Stem-type Thermometer – helps you to determine optimal application temperature for asphalt.

Electric Brakes – standard for models 250 gallons and greater: 12" x 2" electric brake.

Lighting Devices – lights and reflectors are supplied for road use.

Splash Guards – inside the vat and lids help prevent accidental asphalt splash.

Engine Cover – a protective engine cover, which can be locked, is standard on all models.

Heavy Duty Immersion Unit – engineered and insulated for efficient heating, the entire unit may be easily removed for cleaning.

Insulated Flue Stacks – keeps flues from overheating and helps prevent flash fires.

Heavy Duty Tube Units – to maintain maximum temperature without buckling.

Heavy Duty Drainscock – 2-1/2" diameter for faster pouring. Design provides instant opening and closing.

Optional Features:

Fully Automatic Temperature Control – electronic controls turn burners on and off to maintain perfect temperature.

Semi Automatic Hi-Lo Temperature Control – holds material at selected temperature by turning burners to low fire and returning to high fire when cold material is added.

Safety Loader – as pictured on our emissions control kettle. Great for preventing burns or splashes.

EASTERN CANADA

1-888-749-7777

WESTERN CANADA

1-866-338-7727

Optional Features:

- **Tool Box** - lockable heavy duty all steel construction
- **Ladder Racks** - for transporting ladders or thin walled tubing



- **Removable Back Bumper** - for drain-cock protection

Lid Options

Single Lid

Dual Lid



Prevents burn and splash accidents as operator opens lid from reverse side.



Facilitate easy loading from either side.

MK 180 Single Lid Option (load from one side only)



For repairs and smaller less-mechanized crews. • 180 gal capacity (680 L) • single propane burner • 43-1/2" loading height

Regular Lid Option (load from both sides)



MPK 250

Single Lid Option



For semi-mechanized crews requiring a capacity of about 19 kegs of asphalt. • 250 gal capacity (945 L) • single propane burner • 42-1/2" loading height • recirculating system • electric brakes

Dual Lid Option



MPK 350

Single Lid Option



Dual Lid Option



For a highly mechanized crew using a hot tanker. This popular pumper kettle features: • 350 gal (1323 L) capacity • double propane burners • 42-1/2" loading height • recirculating system • electric brakes

MPK 500

Single Lid Option



Dual Lid Option



For highly mechanized crews. This production pumper model is especially suited for use with cold asphalt kegs, heating a full vat to 400°F in under 60 minutes. • 500 gal (1890 L) capacity • double propane burners • 43-1/2" loading height • recirculating system • electric brakes • tandem axles

MPK 800

Dual Lid Option

For very high production crews, this unit provides an extremely large capacity, without sacrificing heating efficiency.

- 793 gal (3000 L) capacity
- double propane burners
- recirculating system
- electric brakes
- tandem axles
- also available in single lid option



E-MAIL

info@canadaspecialty.com

WEB

www.canadaspecialty.com

55-gal Patch Kettle with Wheels

An excellent patch pot with large wheels and wide frame providing excellent stabilization; well-balanced for easy movement around job site.

The SPAR-Marathon 55-gal tank has the flexibility to be used alone or carried by the utility carrier or station wagon, attached by the rod holes through body. Complete with burner, drain cock, and thermometer.



The 55-gallon Patch Kettle, the 55-gallon Insulated Tank and the 55-gallon Insulated Patch Pot may be used with either the utility carrier or the stationwagon carrier. Channel irons securely attach the tank on either carrier.

MK 90 Skid Kettle

- 90 gal. capacity
- heats up quickly
- can be easily hoisted to the roof and fits in most elevators
- very easy to handle and maneuver
- bottom rails make for easy sleigh-like push/pull moving



Economy Patch Kettle

- 40 gal. capacity
- heats up quickly and easily
- for tie ins, small patch jobs and maintenance



55-gal Insulated Patch Pot

For the roofer requiring access to hot asphalt maintained at constant application temperature while on deck. Actually, a completely installed mini kettle that easily attaches to your carrier for time-consuming detail work (such as drains or skylights). Comes complete with vapour torch, hose, regulator, drain cock and thermometer. (Tank only, does not include utility carrier.)

Emissions Control Kettle

Efficient and Effective at Controlling Emissions and Odour



- Use wherever asphalt fumes can affect your customer or your surroundings.
- Impressive control of smoke and smell means no more complaints.
- Use for jobs at: schools, apartment

- buildings and other residential areas, shopping centres, hospitals, office buildings, food processing plants, etc.
- Work any job during normal business hours.

Easy to Operate and Cost Efficient

By turning on the vapour propane burner in the chimney stack asphalt emissions are efficiently burned away – it's that simple. (For complete operating instructions please contact our office or refer to your owner's manual.)

Standard Features

Our emissions control kettle is loaded with the same standard features and benefits as our regular kettles. Our refinements and improvements are the result of almost 50 years of building high quality kettles. Emissions control is available on any size SPAR-Marathon kettle. Also available as a retrofit lid to fit on your existing SPAR-Marathon kettle.

Safety Features

Fire Arrester Screens – Provides protection in the event of a flame backdraft and also protects the chimney burner area from asphalt splashes.

Offset Chimney Design – Provides extra safety. The burner flame is not directly over the kettle opening and is safer than other designs.

Safety Loader – Loading is done through the safety loader which prevents operator burns and splashes and helps prevent smoke and odour from escaping (shown below).



Automatic Temperature Controls – Your choice of fully automatic or semi automatic hi-lo provides maximum control and safety by maintaining asphalt at a consistent temperature.

EASTERN CANADA

1-888-749-7777

WESTERN CANADA

1-866-338-7727

Kettle Accessories



Drain Cock

Heavy duty 2-1/2" diameter for faster pouring



Flex Saver Pipe

Saves wear and tear on Flex Pipe



Pump Coupling Cover

This new safety feature prevents worker's hands, arms and other body parts or clothing from making contact with rotating parts eliminating possible hazards. Can also be ordered as an easy to install part for your in-use kettle.



Miscellaneous Fittings

Unions, Couplings, Etc.



Flex Pipe

Bends by hand to desired angle - Available in 1-1/2" and 2" diameters in 3 foot and 5 foot lengths



Thermometers

4" regular, 12" with easy text handle



Thin-walled Tubing

Available in 1-1/2" and 2" diameters; in 4,6,10 and 20 foot lengths



Regulators & Gauges

ULC Approved Suitable for vapour or liquid withdrawal

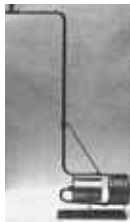

Burner

ULC Approved for any size kettle



Hoses

ULC Approved Variety of sizes for vapour or liquid systems



Hot Tar Hose

- heat resistant rubber flex hose
- 1-1/2" complete with nipple on one end



Swivel Jack



Economy Double Wheeled Barrow

- all steel round tubing frame
- economically priced
- round nose plate reduces surface damage
- 6 cubic foot capacity tray
- use 18 x 850 x 8 tires or 400 x 480 x 8 tires

Single Wheel Barrow



Fork Cart

- easily moves all types of material
- large wheels distribute weight evenly over large area
- designed for one man to move up to 800 lbs.



- same heavy duty all steel construction as our double wheeled barrow
- same large size pneumatic tire
- superb balance and easy discharge
- 6 cubic foot capacity tray



Fork Cart with Helper Wheels

- helper training wheels adjust for easy control
- heavier loads are moved with little effort



Double Wheeled Barrow

Safer

- better balanced; sideways tipping tendency eliminated

Easier

- 30% less lifting effort; easier to control, less fatigue
- round nose plate reduces surface damage
- heavy duty construction. 6 cubic foot capacity tray

E-MAIL

info@canadaspecialty.com

WEB

www.canadaspecialty.com



Side Dumper with Trailer

- large wheels and extended rear axle provides extra stability and safety
- dumper tray mounts and dismounts quickly
- designed for one man to dump full load



Super Tear Off Bar

To complete the job after cutting, use the SPAR-Marathon Tear-Off Bar.

It is equipped with a hardened steel blade, steel wheels and heavy duty construction.

Simply ram it under old roofing, push down on the handle and remove the old roof!



Flat Proof Tire

Available as an option. Provides carefree usage. Solid rubber. Maintenance Free. Flat Free. Lightweight and durable.



Propane Carrier/Lifter

- used for easy movement of propane bottles and safe hoisting
- double chains fully secure tank



4 Tank Propane Carrier/Lifter

Model 4000 Utility Carrier



ROOF CARRIERS

SPAR-Marathon Roof Carriers are an effective method of transporting materials on any flat surface. Rugged, oversize steel frame construction provides reliable movement of bulky items. Large pneumatic tires make a big load move easier. Convenient trailer hookups are standard for more mechanized crews.

Single Ply Roll Carrier

- make easy work of unrolling single ply or moving rolls around jobsite
- consists of two double wheeled handles and one 13' stabilizing tube
- the stabilizing tube's rotating feature permits easy, controlled unrolling and the double wheeled handles allow for easy maneuverability of even the biggest rolls



Stationwagon Carrier

The Stationwagon Carrier is available with regular tires or large balloon tires for extra stability as pictured.

55-gal Insulated Tank

This hot stuff tank is your most economical method for fast, safe transport of asphalt across any roof deck. Complete insulation wrap maintains asphalt at correct application temperature. Quick change channel irons securely supports this tank to our utility or station wagon carriers. Also available with optional thermometer. (Tank only, does not include station wagon carrier.)



Model 3000 Upright Carrier

An alternative to carriers with tank options, the SPAR-Marathon Model 3000 Insulated Carrier for hot asphalt allows safer transport. Simply fill up and hoist to the roof. The most profitable method of moving asphalt up any size of building. Also available with optional thermometer.

Gravel Spreader

The SPAR-Marathon Gravel Spreader will spread gravel evenly across 36" as quickly as an operator can walk.

One simple adjustment sets up gravel flow; one lever provides positive open and close feed control. Adapts to all contemporary graveling applications.

3 large wheels provide the ultimate in maneuverability and stability.

Tubeless pneumatic tires and semi-pneumatic tires make it easy to handle.

Capacity: 5-1/2 cubic feet.





Adhesive Dispenser

Two variable feeds:

- single ribbons on 6" deck
- double ribbons on an 8" deck

Dual wheels that ride on ribs without falling into flutes (10" rubber tires, ball bearing wheels).

Mini Mopper

The SPAR-Marathon Mini Mopper reduces time spent hand mopping, top coating, and dispensing adhesives. The 1 metre (39 1/2") width and 28-gallon capacity ensures that the Mini Mopper will easily pay for itself quickly. Oilite bushings and tubeless pneumatic tires save your energy by increasing maneuverability. Mop at almost any speed, as hot stuff outlets are spaced 1-inch apart; plugs also provided to help regulate the width or volume of desired flow.

Also available in 48" version, by special order.



Mini Adhesive Applicator

Fully adjustable applicator wheel for desired thickness. Small and easy to handle. Ideal for jobs where our full size adhesive dispenser is too big.

**Mini Mopper with Centre Wheel attachment
(shown in the mopping position).**





101 Bucket and Carrier

The SPAR-Marathon Model #101 Bucket and Carrier gently transports hot stuff to where you are mopping.

- ball bearing heavy duty rubber wheels or optional steel wheel version
- bucket detaches from handy tubular steel carrier
- carrier features mop handle support
- bucket capacity: 8 gallons



101 Bucket



#25 Big Bucket

The Model #25 Big Bucket reduces the number of refills needed to finish the job, with its large 25-gallon capacity.

T-bar handle, tubeless pneumatic tires and oilite bushings all add up to time-saving maneuverability.

Dangerous flash fires are reduced by specially designed wind deflector shield.



Non Stick Roof Buckets

Both buckets are all steel, with round bottoms to prevent sticking to roof; features a 'D' type lower handle and a heavy ball type top handle that cannot fall against side. Available in 12" or 14" models.



Pouring Pot

- for pouring asphalt
- comes complete with no-spill lid
- same strong construction as our non-stick roof bucket



Galvanized Bucket

An economical alternative.



No-Spill Bucket

- for hoisting or carrying asphalt
- prevents unwanted asphalt spills
- easy flip safety lid
- same strong construction as our non-stick roof bucket



Bucket Handle

- strengthens regular pails and buckets
- adjustable for different sizes
- reusable
- handle will not fall down and stick to bucket

Roof Hatch

- standard 30"x36" size
- constructed from 16 + 14 gauge Steel
- plated inner & outer handles to withstand weather
- primed with grey oxide primer
- Fibreboard insulation on all sides

**Roof Hatch Safety Rail**

Order it separate or pre-installed on the hatch. With safety being increasingly important, would any building owner say no?

Upsell and add to your profit.

**Water Pump**

- Honda powered
- 1-1/2" suction and 1-1/2" discharge ports for quick removal of water
- comes complete with 6' suction hose, 25' discharge hose and puddle plate

Truck Decks

We can custom make truck decks and mount on your Chassis. Pictured is a 24' 6" deck equipped for a rough terrain forklift.

Our componentry such as cross members, floors and side rails are made heavy duty for harsh uses like steel or roofing supplies.

We can also customize it to your taste with tool or product boxes and custom paint.





Roof Scrapers

- available in 3-1/2" and 7" sizes
- concentrates weight close to roof
- strong construction
- spring steel blades
- replacement blades also available



Asphalt Skimmer

- for skimming debris and film from hot asphalt
- a must for proper kettle maintenance
- adjustable length handle

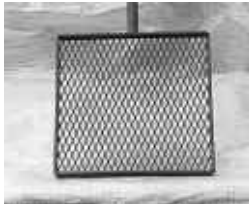

Mop Bellhead

- lightweight aluminum mop heads
- use again and again



Mop Staple

- heavy gauge wire staple



Triple Seamer



Double Seamer

- same strong design as regular seamer



Seamer

- heavy duty steel roller
- strong construction



Rollers & Framers

- regular, short and close naps for various applications
- available in 12" and 18"



Handle

- aluminum handles for mop bellheads, dippers and gravel pushers



Gravel Pusher

- rugged cast aluminum construction
- also available with aluminum tubular handle, priced separately

Dipper

- seamless aluminum dipper
- also available with aluminum tubular handle, priced separately



Roof Brackets

- available in 2" x 10" and 2" x 6" versions



Chimney Caps

- all steel, heavy duty welded construction
- designed to fit snug in chimney flue
- measuring 8" x 8", 8" x 12" or 12" x 12"



Hand Rollers

- incredible heavy duty all steel construction with quality oilite bronze bushings

2" Steel Roller - single fork roller holder allows for use right next to curbs. Slightly rounded roller edge eliminates cutting into roof membrane

2" Silicone Roller - when you need a softer touch for rolling. Single fork design with durable silicone rubber

4" Silicone Roller - single fork roller holder. For use on single ply tapes and seams



Core Cutter

- fast, efficient and easy to use
- makes a hole that can easily be patched
- teeth can be re-sharpened
- designed for durability with hardened steel

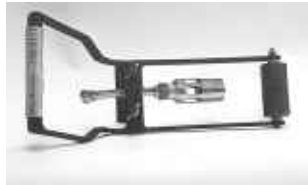

Granular Imbedment Tool

- saves significant time over regular torch and trowel method
- imbeds granulars for proper seaming on modified bitumen



Modified Bitumen Hip Hugger

The Hip Hugger and Hook Bar allow application of modified bitumen without walking on the membrane. Certain modified bitumen, such as S.B.S., should not be walked upon during installation.

Comfortably wraps around so that the strain of pulling the roll is on the legs, instead of the back.

Can also be used to help control the roll in the sloped or vertical applications.



Roll Hook for Mod Bit

Convenient hook design allows for application without walking on the membrane. Angled grip area provides less wrist and arm fatigue.

Rolling Tool Box

Conveniently and safely stores an incredible amount of tools and supplies. 360° swing handle can be swung and locked into place for extra security.

- watertight and fully lockable with protected lock areas
- heavy-duty construction with balloon wheels for easy maneuverability
- adjustable inside shelves
- swinging doors have hooks for smaller items
- front slotted rack for shovels etc.
- large back shelf
- large lockable tool box on reverse side

This unit may be fully removed leaving an extra heavy duty stationwagon style carrier.

**Job Box**

- Recessed tamper proof lock cannot be accessed by bolt cutters, etc.
- leave your tools in your truck or jobsite without fear of theft
- recessed handles
- heavy duty construction
- can be moved by forklift or crane



Hydraulic Dump Trailers

When we designed our line of hydraulic dump trailers we talked to the people that mattered – the professional roofing contractor. We found out what they liked and disliked about other models in the market. Our lineup hits the nail on the head in providing professionals what they are looking for.

Standard Features:

- Frame –** HSS tubing construction
- Dump Body –** HSS tubing construction
- Axles –** 2 heavy duty axles
- Hitch –** Height adjustable pintle ring or ball hitch to suit your towing truck.
- Brakes –** All wheels are equipped with electric brakes
- Lighting –** All lights are wired in compliance with CMVSS and NHTSA
- Reflectors –** Reflectors and reflector tape installed with above compliances
- Hydraulics –** Equipped with one way pump and quick return valve or an optional two way pump with remote dump control. Remote dump control is standard on HD models

- Wheel Jack –** Equipped with jack on all models
- Safety Chains –** Equipped with safety chains on all models
- Lift Cylinder –** Heavy duty lift cylinder

Optional Features:

- rolling cover tarpaulin
- remote dump control (standard on HD models)
- custom paint colour
- high side walls



Heavy gauge steel and extra cross supports provides ultra sturdy frame and dump body.



TR100 HD (regular size sides)
Planks slide in side holders to increase wall height

| | TR100HD | |
|-----------------------------|---------|-------------|
| Load Capacity: | | 10,000 lbs |
| Gross Vehicle weight: (GVW) | | 12,000 lbs. |
| Dump Body Size: | | 6 x 10 ft. |
| Dump Body Height: | | 40 in. |
| Axles: | | 2-6000 lbs. |
| Tires: | | 8-14.5 LT |
| Lifting Cylinder: | | 4-1/2 in. |

*We also manufacture
custom trailers.*

Whether you want a custom size trailer, with sides or without, dumping or non-dumping, or simply some custom attachments or features we're here to help.



TR100 HD
(high side wall option)



SHEET METAL EQUIPMENT

Lok-Former

An excellent hand tool for forming 'S' locks on sheet metal flashings. Made from heavy gauge steel for maximum bending support. Available in 12" and 18" versions.

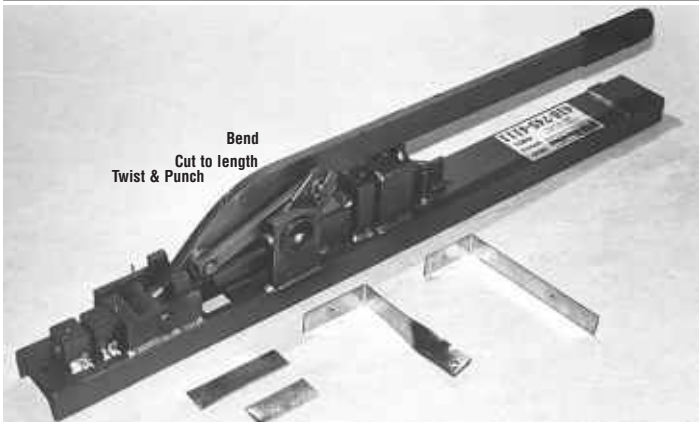

Bandmaster Tool Mark II

Get 3 ton punching power in a Bandmaster Mark II metal working tool.

Four tools in one!

- the Bandmaster Mark II twists, punches, bends and shears heavy gauge band iron or steel hangers (up to 1/8" x 1-1/4")
- twists 90° for ductwork hangers
- punching pressure equals about 6000 lbs. using standard punches and dies 1/16" to 7/16"

- supplied with 9/32" punch and die
- bending is effortless with long handle
- shearing blades reversible for double cutting life

Make duct hangers right on the job!

The ultimate in portability, the Bandmaster Mark II weighs about 35 lbs. and measures approximately 36" x 6" x 3". Add a handy, twisting, punching, bending and shearing Bandmaster to your crew today.

| Punch Capacity Chart | | | | |
|----------------------|-------------|--------------|-------------|--------------|
| Punch Diameter | 1/16 - 9/32 | 19/64 - 5/16 | 21/64 - 3/8 | 25/64 - 7/16 |
| Gauge Capacity | 10 | 11 | 12 | 14 |



48" Gang Slitter

Standard Features

This heavy duty 'pull through' type slitter was designed for use by roofers and sheet metal contractors.

- rugged frame for years of solid, accurate slitting
- gear and chain drive with safety guard
- precision ground, high carbon, high chrome tool steel knives as standard equipment (can be reground for extended life)
- three pairs of cutting knives supplied standard
- heavy gauge steel table for supporting sheets
- precision ground shafts mounted between flanged bearings
- sheet guide on both sides for safe and accurate slitting
- easily adjustable for light or heavy gauge

Specifications

- sheet capacity: 48" (1220 mm) wide
- shafts: 3" (76 mm) diameter
- cut capacities

| Metal Gauge | Max. No. of Cuts | Metal Gauge | Max. No. of Cuts |
|-------------|------------------|-------------|------------------|
| 30 | 6 | 20 | 2 |
| 28 | 4 | 18 | 1 |
| 26 | 3 | 16 | 1 |
| 24 | 3 | | |

- cutting speed: 40 feet per minute (0.2 m/sec.)
- table height: 33-1/2" (850 mm)
- shipping weight: 640 lbs. (259 kg)

Calibrated Back Gauge



Floor Model Plain Brakes

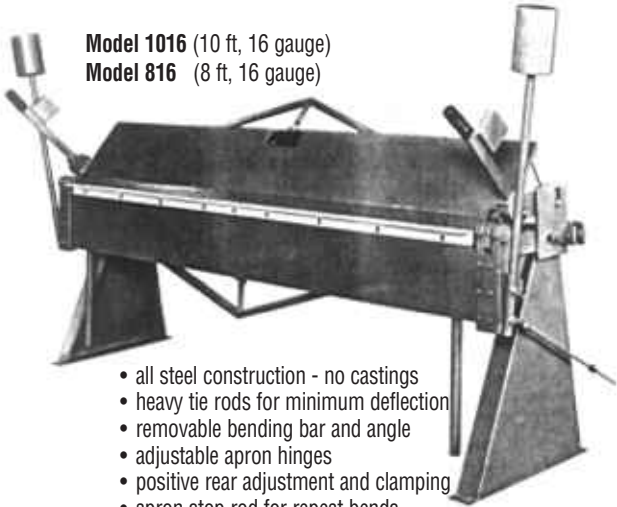

Model 1016 (10 ft, 16 gauge)
Model 816 (8 ft, 16 gauge)

- all steel construction - no castings
- heavy tie rods for minimum deflection
- removable bending bar and angle
- adjustable apron hinges
- positive rear adjustment and clamping
- apron stop rod for repeat bends
- replaceable bushings and bronze hinge pin
- long handles for extra leverage
- full capacity, 1" flange, bar and angle in place
- improved leg design for neat appearance and lighter weight.

| | |
|--|---|
| Also available is a wide selection of Sheet Metal Equipment and manually-operated fabricating tools: | Punches and Presses, Notchers, Benders, Shears, Formers, Beading, Crimping and Seaming Machines |
|--|---|

Model 422
Bench Brake
(4 ft, 22 gauge)

Weighs only 210 lbs, including skids. Two men can handle it easily, taking it out on the job or moving it to the most convenient spot in the shop to suit the job at hand.





Bend trimwork on the jobsite like a PRO

- Stores material inside brake - reduces handling and flipping of material.
- Patented "Moving Pivot Hinge" increases bending power without marring material.
- 180° hemming capability for making more rigid panels.
- Available in 8'6", 10'6" and 12'6" lengths.

***MAX+MUM XL System
Includes MAX+MUM II™ Brake, MAX
Snap Stand with Wheel Kit and
adjustable MAX Cut-Off***



- Bends and forms commercial metals on the job site.
- Patented "Moving Pivot Hinge" increases bending power without marring materials.
- 180° hemming capability for making more rigid panels



Side-Winder™

Keeps the coil at your side where you need it!

- Allows you to feed coil directly into the jaws of your PRO Brake.
- Attaches in seconds to PRO 19 brakes.

Angle Gauge

Take the guess work out of your bends

- Mounts easily on any PRO, MX Series, or MAX-I-MUM II brake built after 1995.
- Quickly shows the bending angle.



Snap Stand®

Solid support for your portable brakes and saw tables.

- Legs adjust independently to level on uneven ground.
- Brakes and Saw Tables easily snap and lock in place.
- Folds flat for easy storage.
- Sets up in seconds.
- Optional Wheel Kit: Easy to attach, Steel hub, 10" pneumatic tires.

PRO™ Cut-Off

Quickly and safely make factory quality cuts right on your brake.

- Lightweight aluminum construction built to last.
- Eliminates use of dangerous utility knives and open blades.
- For use with all PRO Series Brakes (1995 and after).
- Includes molded storage case.

Canada Specialty Products

SPAR-Marathon



Echo Blower

- 44.0 CC engine
- electronic ignition for fast, easy starts
- light weight – only 22.3 lbs.
- padded backrest for user comfort

Little Wonder High Output Blower

- blows away the competition
- computer designed impeller
- “ever widening” housing & split stream discharge
- 8 HP Briggs & Stratton or Honda engine



SPAR-Marathon Equipment is powered by Briggs & Stratton® or Honda engines.
We also service and repair what we sell. Parts are also available.

EASTERN CANADA
1-888-749-7777

WESTERN CANADA
1-866-338-7727

Powered by

HONDA
ENGINES

GX120 - Specifications:

Engine Type: Air Cooled 4 Stroke OHV
Piston Displacement: 118 cm³
Bore x Stroke: 60 x 42 mm
Max. Horsepower: 4.0 HP
Max. Torque: 0.75 kg-m/2,500 RPM
Fuel Tank Capacity: 2.5 litres



GX160 - Specifications:

Engine Type: Air Cooled 4 Stroke OHV
Piston Displacement: 763 cm³
Bore x Stroke: 68 x 45 mm
Max. Horsepower: 5.5 HP
Max. Torque: 1.1 kg-m/2,500 RPM
Fuel Tank Capacity: 3.6 litres

GX270 - Specifications:

Engine Type: Air Cooled 4 Stroke OHV
Piston Displacement: 270 cm³
Bore x Stroke: 77 x 58 mm
Max. Horsepower: 9 HP
Max. Torque: 14.1 lbs-ft./2,500 RPM
Fuel Tank Capacity: 6 litres



GX340 - Specifications:

Engine Type: Air Cooled 4 Stroke OHV
Piston Displacement: 337 cm³
Bore x Stroke: 82 x 64 mm
Max. Horsepower: 11 HP
Max. Torque: 17.4 lbs-ft./2,500 RPM
Fuel Tank Capacity: 6.5 litres

PAS 2400 Power Source

Featuring 23.6 cc Commercial Grade Engine for Outstanding Power in Professional Use

**ProSweep Attachment**

- 28GA Nylon Bristles
- over 22" of swath for all your sweeping needs

**GUNOOK SUPER HOOK™** Professional's Choice**DEMOLITION DEMON*****Air Powered Shingle and Nail Removal***

- *Fast • Easy • Powerful*
- *Durable • Lightweight*
- *\$\$\$ in your pocket*
- *Increase productivity*
- *Rapid return on investment*
- *Do more jobs with fewer people*





Industrial Grade Sprayer

- Tri-poxy coated metal construction
- 3.5 GAL/13.2 L capacity

V-Belts

Wide Variety of sizes stocked



Replacement Wheels

Large selection of sizes for all your equipment needs

Abrasive Cutoff Wheels

For Portable Gas and Electric Saws

- concrete, masonry
- metal, stainless
- heavy duty
- 12" x 1/8" x 1"
- 12" x 1/8" x 20mm



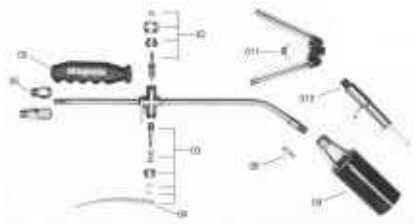

Magnum Components

| Product Code | Description |
|--------------|------------------------------|
| 02..... | Pilot Assembly |
| 03..... | Flame Regulator Assembly |
| 04..... | Lever Handle |
| 05..... | Plastic Handle |
| 06..... | Swivel Hose End Fitting |
| 08..... | Gas Orifice |
| 09..... | 50mm Nozzle |
| 010..... | Electronic Ignition Assembly |
| 011..... | Spring Safety Stand |



Magnum Torches

- available with 10", 16" and 24" extension tubes
- optional electric start available on 16" model

Torch components. Can be assembled to make custom torch sets.



Propane Soldering Iron

- adjustable pencil point flame
- uses standard propane hose
- replaceable copper ends
- durable steel construction
- removable stand

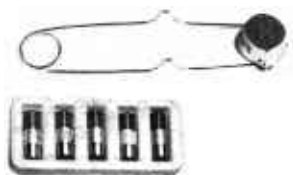

MP-1 Lighter

- single flint, cup type lighter

MP-2-5 Flints

- holder of 5 flints for MP-1 lighter



Galvanized Soldering Pot

For use with charcoal

Propane Soldering Furnace

A well-constructed furnace with brush flame burner

BTU's: Approx. 43,200

Gas Usage: Approx. 25 lb/hr.

Shown with optional cowl



STEINEL®



HG 3002 LCD heat gun

- temperature: continuously variable 120 °F – 1100 °F
- LCD: displays temperature output in 10 °F increments CSA approved
- accepts a full range of nozzles and accessories

HG 4000E Heat Gun

- airflow: up to 21 CFM
- temperature: Selectable from 80 °F – 1100 °F
- LCD: displays actual and target temperatures in 10 °F increments
- accepts a specially designed range of nozzles and accessories



TES-1326 Infrared Thermometer

Electronic measuring tool for precise determination of surface temperatures. Hot spots can smolder for hours before catching fire. This tool allows you to check the site before you leave. No modified bitumen torch down job should be complete until you check the job with the Thermo-Check. Worries about smoldering fires that you can't detect until it is too late are thing of the past.

- °C/°F selectable
- back light LCD display
- laser targeting
- -20°C – 500°C (-4 °F – 932 °F) range
- audible and visible alarm



PLASTIC WELDING



VARIMAT V

This tried and tested automatic welding machine for roofing membranes is now better than ever; the new VARIMAT V also displays voltage and welding seam length. A model specifically for overlap welding of elastomer bitumen is also available.

- Overlap welding of PVC-P, ECB, EPDM, CSPE and TPO roofing membranes as well as elastomer bitumen
- Easy welding, also of homogenous and thin roofing membranes
- Wrinkle-free welding up to 5 m/min
- Patented pendulum pressure roller guarantees uniform pressure also on uneven surfaces
- Digital display of set and actual values of welding speed and temperature
- Constant temperature and speed independent of voltage fluctuations and ambient temperature

TRIAC S



Triac S: the reliable, cost-effective and proven hand tool with steplessly controlled temperature

- Adaptor tube with heat protection
- Electronic heating element protection
- Motor shut-off at minimal carbon level
- Multiple replacement of carbon brushes possible
- Suitable for continuous operation
- Please ask for various nozzles sold separately

TRAMEX



Dec Scanner
Roof Moisture Detector

DEC SCANNER

A mobile instrument on four wheels which allows quick non-destructive scanning of large roof areas with immediate accurate results. The Dec Scanner works on most types of built up and single ply non-conductive roofing with smooth or ballasted surfaces.

Pictured above

SURVEY ENCOUNTER

The intelligent moisture metre

The world's most advanced and versatile non-destructive moisture metre for measurement and recording of moisture in building materials such as wood, drywall, roofing, plaster, brick, siding etc. Based on micro controller technology it offers data storage, different material libraries, automatic correction for different wood species and temperature. Supplied with PC interface and software compatible with Windows 95/98 word processing and spread sheet programs.

Not pictured

Roof and Wall Moisture Scanner



Multi-mode moisture scanner for non-destructive moisture detection and leak tracing in the building envelope including:

- Built-Up
- Non-Conductive Single Ply
- Modified and Foamed Roofing Systems
- Exterior Insulation and Finishing Systems

The **RWS** incorporates two of Tramex's well-known moisture scanners, the Leak Seeker for roofing, and the Wet Wall Detector for EIFS, Incorporating all the benefits and features of both these time proven instruments into this one instrument.

The **Tramex RWS** has dual operating modes for EIFS and Roofing. Each of these modes has 2 ranges of sensitivity for both deep and low penetration sensitivity, enabling the scanning of Roofing, and EIFS, with a signal penetration ranging from the surface up to approximately 4" (100 mm).

SHINGLE SHEAR™

Shingle Shear

- fast, easy and accurate cutting of all types of asphalt and fibreglass shingles
- inlaid tape measure and angle guide
- fits over a bundle of shingles for easy raising and leveling
- flip up cleat for steep pitched roofs
- adjustable straight edge for cutting starters
- lightweight— only 18 LBS
- replacement blades available



Digital Pitch Finder

- displays roof pitch readings in inches of rise per foot
- no need for two-handed measurements or conversion calculations
- a must for estimators and shinglers



Portable, Submersible, Centrifugal Pump

For a wide variety of applications. Can be used with standard garden hose.

FEATHERLITE

INDUSTRIAL LADDERS



Series 3200 I Beam Side Rail

CSA Approved Grade 1 - 250 lb. Load Rating

Meets or Exceeds ANSI Type A - 300 lb. Load Rating

- heavy duty "I" beam construction, 3-1/16" x 1-1/4" rails provide stability, torque resistance and high strength to weight ratio
- heavy duty serrated rungs prevent slipping for safe and sure climbing
- yellow ABS Cyclocac, high impact, non marring end caps
- heavy duty spring-loaded die cast rung locks
- heavy duty swivel feet c/w cog wheel

Two Section Extension – D-Rung

| Part No. | Size | Maximum Extended Length | Outside Width | Approx. Weight (lbs.) |
|----------|------|-------------------------|---------------|-----------------------|
| 3220 | 20' | 17' | 17-5/8" | 36 |
| 3224 | 24' | 21' | 17-5/8" | 43 |
| 3228 | 28' | 25' | 17-5/8" | 53 |
| 3232 | 32' | 29' | 17-3/4" | 60 |
| 3236 | 36' | 32' | 17-3/4" | 69 |
| 3240 | 40' | 35' | 17-3/4" | 77 |

Series 4200 Box Section Side Rails

Our Signature Product – possibly the best designed and manufactured ladder in the world!

- rigid "box section" side rails, unequalled for strength and durability
 - side rails:
 - 2-7/8" x 7/8" – 4200's up to 32'
 - 3-1/4" x 1" – all other sizes
- side-mounted rope pulley and slide guide system keeps rope clear of climber's feet and allows effortless raising and lowering of fly section
- impact-resistant yellow ABS Cyclocac end caps
 - heavy duty zinc die cast rung locks
- cross ribbed rubber safety shoes c/w ice pick

Two Section Extension

| Part No. | Size | Maximum Extended Length | Outside Width | Approx. Weight (lbs.) |
|----------|------|-------------------------|---------------|-----------------------|
| 4216 | 16' | 13' | 17-1/16" | 29 |
| 4220 | 20' | 17' | 17-1/16" | 37 |
| 4224 | 24" | 21" | 17-1/16" | 44 |
| 4228 | 28' | 25' | 17-1/16" | 50 |
| 4232 | 32' | 29' | 17-1/16" | 69 |
| 4236 | 36' | 32' | 18-3/8" | 78 |
| 4240 | 40' | 35' | 18-3/8" | 86 |
| 4244 | 44' | 39' | 18-3/8" | 94 |

Three Section Extension

| Part No. | Size | Maximum Extended Length | Outside Width | Approx. Weight (lbs.) |
|----------|------|-------------------------|---------------|-----------------------|
| 4360 | 60' | 50' | 21-3/4" | 128 |



E-MAIL

info@canadaspecialty.com

WEB

www.canadaspecialty.com



FEATHERLITE
INDUSTRIAL LADDERS

**Extra Heavy Duty Fibreglass
Extension Ladders Series 6200**

CSA approved Grade 1 - 250 lb load rate
Meets or exceeds ANSI Type 1A - 300 lb load rate

- durable non-conductive side rails in high visibility safety yellow
- riveted rung to rail design for easy repair
- heavy duty spring loaded die cast rung locks

| Part No. | Size | Maximum | | Base Section | | Fly Section | | Approx. Weight (LBS) |
|----------|------|-------------|---------------|--------------|---------------|--------------|-----|----------------------|
| | | Open Length | Outside Width | Inside Width | Outside Width | Inside Width | | |
| 6216 | 16' | 13' | 17-3/8" | 15" | 16-5/8" | 14-1/4" | 38 | |
| 6220 | 20' | 17' | 17-3/8" | 15" | 16-5/8" | 14-1/4" | 44 | |
| 6222 | 22' | 19' | 17-3/8" | 15" | 16-5/8" | 14-1/4" | 48 | |
| 6224 | 24' | 21' | 17-3/8" | 15" | 16-5/8" | 14-1/4" | 52 | |
| 6228 | 28' | 25' | 17-3/8" | 15" | 16-5/8" | 14-1/4" | 59 | |
| 6232 | 32' | 28' | 17-3/8" | 15" | 16-5/8" | 14-1/4" | 66 | |
| 6236D | 36' | 32' | 19" | 15-1/2" | 17-3/4" | 14-1/4" | 96 | |
| 6240D | 40' | 35' | 19" | 15-1/2" | 17-3/4" | 14-1/4" | 106 | |



Ladder Hook with Latch and Wheel

- swivel plate allows ladder to be placed in valley between gables
- plate prevents hook from damaging asphalt shingles

Ladder Arms

- holds ladder away from wall
- gives a comfortable and safe working position for painting window sash, working on gutters, etc.
- quickly clamped to ladder with wing nuts





Medium Duty Aluminum Step

CSA Approved Grade 2 - 225 lb. Load Rating
 Meets or Exceeds ANSI Type 2 - 225 lb. Load Rating
 The Finest Tradesman Step On The Market

- super tough moulded copolymer utility top
- durable yet light weight extruded side rails
- 3" slip-resistant serrated steps
- self-folding pail tray
- 'J' shaped spreader arms
- heavy duty rubber safety shoes



| Part No. | Open Size | Open Height | Highest Safe Standing Height | Base Width | Base Depth | Approx. Weight (LBS) |
|----------|-----------|-------------|------------------------------|------------|------------|----------------------|
| 2405 | 5' | 56" | 34" | 20" | 38" | 12 |
| 2406 | 6' | 67" | 45" | 21" | 44" | 14 |
| 2407 | 7' | 79" | 56" | 22" | 50" | 17 |
| 2408 | 8' | 90" | 67" | 23" | 56" | 20 |
| 2410 | 10' | 112" | 90" | 26" | 70" | 24 |

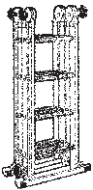

Extra-Heavy Duty Articulating Ladder Part No. 3316

CSA Approved Grade 1 - 250 lb. Load Rating
 Meets or Exceeds ANSI Type 1A - 300 lb. Load Rating
 • A 15 ft. Straight Ladder, 8 ft. Step Ladder, 4 ft. Scaffold

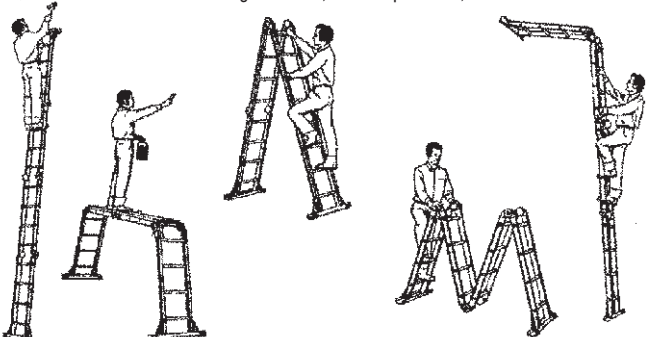

EASTERN CANADA
1-888-749-7777

WESTERN CANADA
1-866-338-7727

JAWS
LADDERS
TELESCOPIC CLIMBING SYSTEM

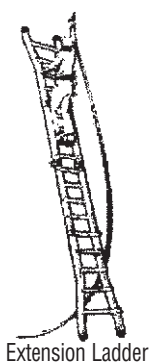

Extension Ladder

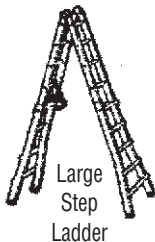

Large Step Ladder



Staircase Ladder

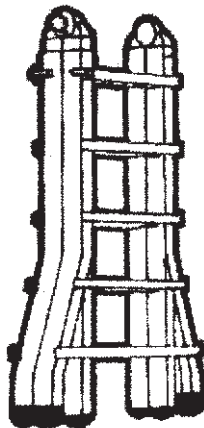

Type 1A
Extra Heavy Duty
300 lb workload



Scaffold



Flush Step Ladder

| Model No | Folded Height | Extension Range | Working Height | Step Ladder Range | Scaffold Height | Weight |
|----------|---------------|-----------------|----------------|-------------------|-----------------|--------------|
| ULT 22 | 5' 9" | 11' to 19' | 11' to 22' | 5'6" to 9'6" | up to 5' | 41 lbs-18 kg |
| ULT 26 | 6' 9" | 13' to 23' | 13' to 26' | 6'6" to 11'6" | up to 6' | 50 lbs-23 kg |



Heavy Duty Sawhorse

FEATHERLITE

INDUSTRIAL LADDERS



99112

Gravity Locks*

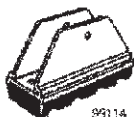

99114



99116

Swivel Safety Feet*

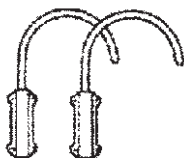

Folding Roof Hooks*

*Universal Size: Fits all Featherlite Ladders

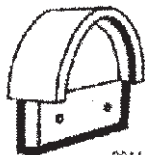

99113

3200 Series

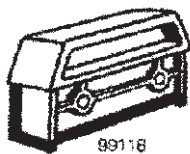

99118

4200 Series

End Caps

Stand Off Brackets

Holds ladder away to prevent damage to eave-strough

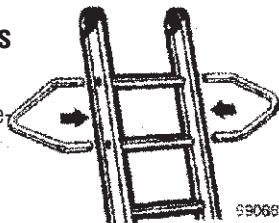

99068



Medium Duty Extension Ladders

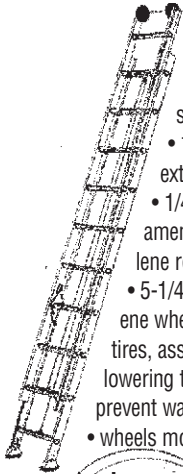

- rib reinforced interlocking channel side rails 3" x 1"
- pressure zinc die cast gravity ladder locks with stainless steel springs
- 1-1/2" dia. high impact polystyrene pulley on heavy duty extruded aluminum bracket aligns rope in direction of pull
- 1/4" dia. mono-filament polypropylene rope
- 5-1/4" dia. polyethylene wheels with PVC tires, assist raising and lowering the ladder and prevent wall marring
- wheels mounted on solid aluminum axles

| Model No. | Nominal Length | Working Length | Mass |
|-----------|----------------|----------------|---------|
| 5716-2 | 16' | 13' | 11.0 kg |
| 5720-2 | 20' | 17' | 13.5 kg |
| 5724-2 | 24' | 21' | 16.0 kg |
| 5728-2 | 28' | 25' | 20.5 kg |
| 5732-2 | 32' | 28' | 23.5 kg |
| 5736-2 | 36' | 32' | 27.5 kg |
| 5740-2 | 40' | 36' | 31.5 kg |

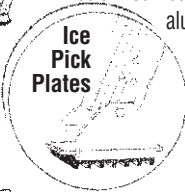

Ice Pick Plates

- CSA certified

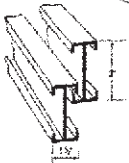

Extension Ladders – 2 Sections Grade 1

| Model No. | Nominal Length | Working Length | Width | Mass |
|-----------|----------------|----------------|---------|---------|
| 7716-2 | 16' | 13' | 20-1/4" | 14.5 kg |
| 7720-2 | 20' | 17' | 20-1/4" | 17.4 kg |
| 7724-2 | 24' | 21' | 20-1/4" | 20.4 kg |
| 7728-2 | 28' | 25' | 20-1/4" | 24.3 kg |
| 7732-2 | 32' | 29' | 20-1/4" | 30.3 kg |
| 7736-2 | 36' | 32' | 20-1/4" | 33.8 kg |
| 7740-2 | 40' | 36' | 20-1/4" | 41.4 kg |

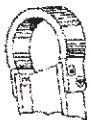



RENEGADEXT™ OVER THE CAB UNIVERSAL TRUCK RACK

- fits every pickup truck in the world!
- heavy-duty 14-gage steel tubing
- adjustable width and length
- camper shell brackets to fit around camper shells
- weight capacity:
1,000 lbs. mounted to bed rail
750 lbs. mounted to camper shell brackets
- high gloss black powder coat finish
- includes locking pins for quick removal of rear bar for taller loads
- three cross rails
- UPS acceptable
- ships in one carton...One SKU!
- ladder positioners and additional cross rails available
- 32" RENEGADEXT™ (Model 81452) is available for taller camper shells and pickup cabs



Steel 250 Series

- high gloss black or white powder coat finish
- 1-3/4" square, 14-gauge tubing
- 1/8" tread plate upright
- support arm telescopes from 24" to 36" for wider loads
- 250 lbs. load capacity
- compliments tool boxes and like accessories
- rack carries ladders both vertically and horizontally

Right: Easy installation: Rack slips into the truck bed mounting post and secures to the bed rail with a collared "U" bolt. When rack is removed, the "U" bolt and mounting post is all that remains, leaving bed free of unwanted fixtures.

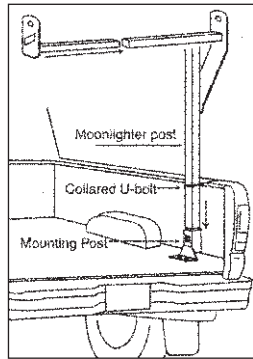

Steel 600 Series

- mounts to rain gutter
- 4" wide uprights made from 3/6" thick diamond tread plate steel
- 1-1/2" & 1-1/4" square steel tubing
- weight Capacity: 600 lbs.
- 9/16" wrench is only tool required for installation
- adjusts from 41" to 70"
- available in high gloss black or white
- additional bars are available

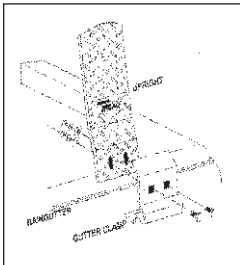

Detailed diagram showing patented clamping system used on all Cross Tread gutter mount van racks.

THE qual-craft® SCAFFOLDING SYSTEM

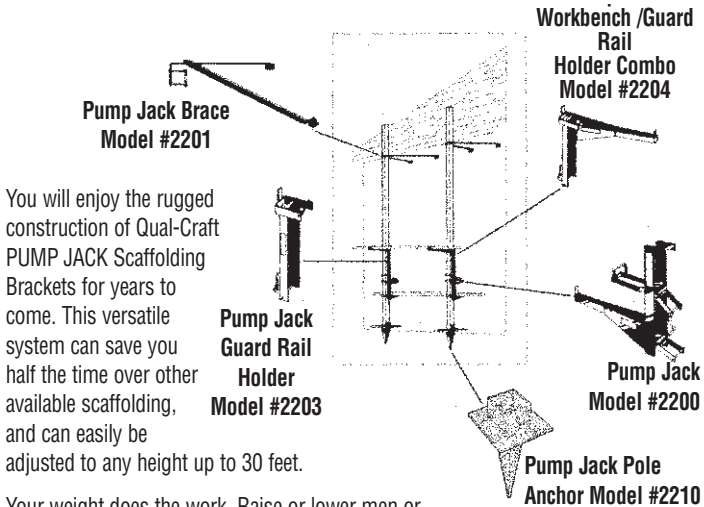

You will enjoy the rugged construction of Qual-Craft PUMP JACK Scaffolding Brackets for years to come. This versatile system can save you half the time over other available scaffolding, and can easily be adjusted to any height up to 30 feet.

Your weight does the work. Raise or lower men or equipment with this versatile bracket. The Pump Jack is held secure to wood poles with a Positive Double Lock System. Raise to position with foot pump and lower with crank.



Aluminum Ladder Jack

- lightweight
- easily adjustable
- will take up to 18' platform



Steel Ladder Jack

- will take up to 20' platform
- all-steel construction
- use inside or outside ladder
- adjusts to fit any pitch
- folds compactly for storage

SPAR-Marathon



| Galvanized Aircraft Cable | | | |
|----------------------------------|--------------------|---------------------------|---------------------------|
| Size in Inches | Diameter in Inches | Breaking Strength in Lbs. | Weight in Lbs per 1000 Ft |
| 5/32" | 0.1562 | 2800 | 45 |
| 3/16" | 0.1875 | 4200 | 65 |
| 1/4" | 0.2500 | 7000 | 110 |

| Pre-Cut Lengths Available | | | | | | | |
|----------------------------------|------|------|------|------|------|------|------|
| 5/32" | 75' | 130' | | | | | |
| 3/16" | 100' | 150' | 200' | 250' | 300' | 350' | 400' |
| 1/4" | 100' | 150' | 200' | 250' | 300' | 350' | 400' |

Pre-cut lengths are complete with sleeve and thimble. Custom lengths available by special order.



Safety Hooks and Snaps



Oval Sleeves



Galvanized Cable Thimbles

Heating Cables

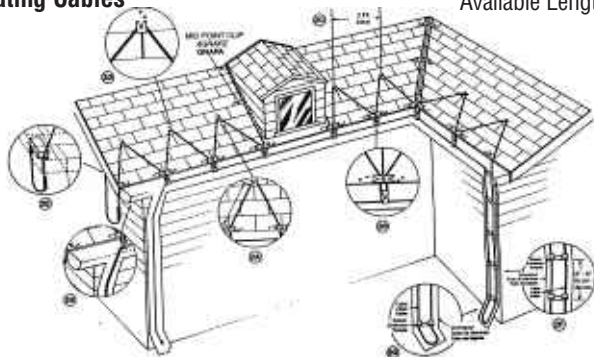

Available Lengths: 40 ft.
60 ft.
100 ft.
175 ft.
250 ft.

Great for eavestrough, roof edge, downspout de-icing and for melting a path for water flow to roof drains.



The excellence of its design ensures the smooth, easy, one-hand operation of the cover—the hallmark of the Bilco Type "S" roof scuttle. This important safety characteristic, combined with rugged construction and dependable operation, assures your customer of the very best in roof scuttle performance. In addition, all Bilco roof products now feature the Bilclip™ flashing system for a faster, more effective installation on single-ply roofs. Bilco, your assurance of quality and value since 1926.



The Type "S" roof scuttle shown to you with the Bilco Ladder™ safety-roof ladder (available separately). The spring-balanced post allows quick and easy-to-load ladders and provides the security of being able to enter or exit air through the scuttle extended beyond the roof level.

30" x 36" stocked
Other sizes available
Custom sizes available



Also available:

Bil-Guard™
Hatch Rail System

EASTERN CANADA
1-888-749-7777

WESTERN CANADA
1-866-338-7727

Canada Specialty Products*New Products*

Watch for future additions to our product line up.

We're actively engineering and building new equipment and products to keep you on the forefront of the roofing industry and to make your job easier.

And we're always on the lookout for new and exciting products available to our industry and we're committed to bringing them to you.

Canada Specialty Products

Canada Specialty Products

At Canada Specialty Products, our employees make the difference.

We're:

- **focused on customer service**
- **more knowledgeable**
- **better trained**

From our warehouse, delivery and manufacturing staff to our inside and outside sales staff.

Canada Specialty Products

A WORLD OF ROOFING PRODUCTS AVAILABLE
THROUGH LEADING DISTRIBUTORS

